

Secoroc Rock Drilling Tools

Secoroc Aqua 60 down-the-hole hammer



Unique technology for cleaner waterwells

The Secoroc Aqua 60 is an ingenious DTH hammer that uses water instead of oil as its lubricant. With this new water-lubricant technology, the Aqua 60 leaves no trace of oil in the drill hole, or in the water table. Clean fresh water can be drawn from the well almost immediately.

The heart of the Aqua 60 is a specially designed piston. This piston uses strategically placed non-metallic wear bands. When the injected water contacts these wear bands, they expand, creating an excellent seal for optimum efficiency.

Performance is not sacrificed in the Aqua 60. In fact it is as high as many of the other hammers offered by Secoroc.

Maintenance is simple. Replacing the wear bands at regular intervals brings the Aqua 60 back to out-of-the-box performance levels.

Operators of the Aqua 60 save substantial amount of money by not having to purchase petroleum hammer oil.

They are also able to offer their customers cleaner water wells.

A proven product with excellent results is now available on a global basis. Partner the Secoroc Aqua 60 with Secoroc Premium Plus bits for a winning combination.

Atlas Copco

Aqua 60 specifications

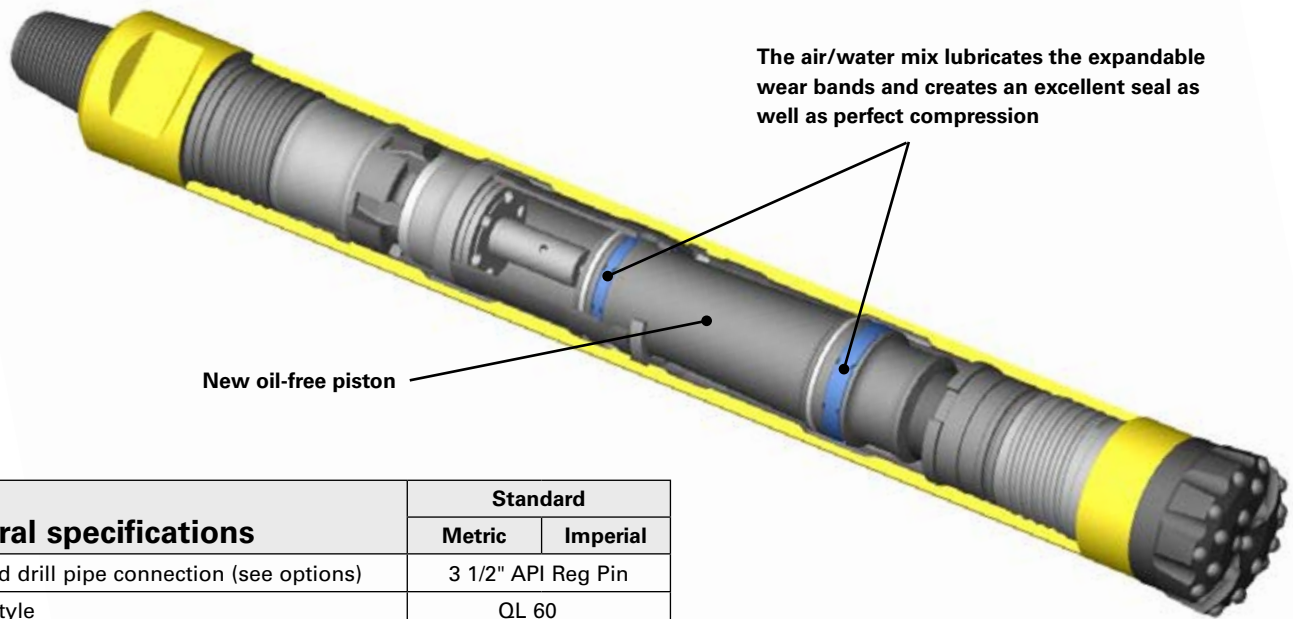

General specifications	Standard	
	Metric	Imperial
Standard drill pipe connection (see options)	3 1/2" API Reg Pin	
Shank style	QL 60	
Outside diameter (mm & in)	138,2	5.4
Length w/o bit shoulder to shoulder (mm & in)	1131,8	44.6
Length with bit extended (mm & in)	1256,3	49.5
Length with bit retracted (mm & in)	1220,7	48.1
Weight w/o bit (kg & lb)	90,9	200,0
Backhead across flats (mm & in)	2 x 4 AF	
Minimum bit size (mm & in)	152,4	6.0
Maximum bit size (mm & in)	215,9	8.5
Bore (mm & in)	114,3	4.5
Piston weight (kg & lb)	19,4	42.6
Stroke (mm & in)	95,3	3.8
Maximum pressure differential (bar & psi)	24,1	350.0
Make-up torque (Nm & ft-lb)	8124,0	6000.0

Part information			Connections	3 1/2" API Reg Pin	3 1/2" API Reg Box
Product No.	Product code	Description			
51903326	9706-05-53-00	Aqua 60	X		
52333739	9706-06-53-08	Aqua 60			X
52296845	9706-05-53-07	Aqua 60 Hydrocyclone	X		
52287752	9706-00-53-00-040	Aqua 60 E-kit (no backhead incl)			

Bits - Description	Product No.	Product code
152 mm (6"), Flat front	90515694	100-5152-26-1217,08-20
156 mm (6 1/4"), Flat front	90515691	100-5156-26-1217,08-20
165 mm (6 1/2"), Flat front	90515613	100-5165-26-1217,08-20
203 mm (8"), Flat front	90514807	100-5203-26-1251,08-20
152 mm (6"), Concave	90515677	100-5152-26-0217,08-20
156 mm (6 1/4"), Concave	90515684	100-5156-26-0217,08-20
165 mm (6 1/2"), Concave	90515616	100-5165-26-0217,08-20
203 mm (8"), Concave	90514315	100-5203-26-0251,08-20
Foot valve	90514253	9283
Assembly tool	89001230	9188

Air consumption		
10,3 bar/150 psi (l/s & scfm)	203	431
Blows per minute (bpm)	1370	
13,8 bar/200 psi (l/s & scfm)	264	561
Blows per minute (bpm)	1470	
17,2 bar/250 psi (l/s & scfm)	327	695
Blows per minute (bpm)	1570	
20,7 bar/300 psi (l/s & scfm)	392	832
Blows per minute (bpm)	1670	
24,1 bar/350 psi (l/s & scfm)	458	973
Blows per minute (bpm)	1770	

Atlas Copco Secoroc offers a wide range of bit body designs and button inserts to meet your specific drilling requirements. Contact your local sales office for details.



Atlas Copco Secoroc AB
 Box 521, SE-737 25 Fagersta, Sweden
 Phone: +46 223 461 00
 E-mail: secoroc@se.atlascopco.com
www.atlascopco.com